

Project #4

The Fiendmaster: A Dallas Rangemaster Spinoff

v01, 01.09.12

Introducing Project #4

This is a modernized version of the Dallas Rangemaster — the overdrive circuit that put the punch in a huge percentage of British rock in the years surrounding 1970. We're talking Clapton, Page, May, Townshend, Bolan, Ronson, Iommi — those guys.

This is a relatively easy project, and a contender for a first build. Still, I recommend building Project #1 first, or at least reviewing it carefully, because it introduces many parts and build techniques used here.

On the other hand, if you've built pedals before, dive right in — the water is *scalding!*

But please read this document through before starting, since you'll have several options along the way, and you may want to plan and choose parts accordingly.



Germanium Transistors: The Upside

This is our first project to use a germanium transistor.

Germanium was used extensively in electronic component production the 1950s and '60s, but was abandoned in favor of silicon components, which boasted superior performance, consistency, and value. Today no one cares about rare and finicky germanium components except certain audio geeks — especially the ones who play guitars.

It's difficult to describe the unique qualities of germanium transistors, though the words “smoother and spongier” seem relevant. They also have a distinctive harmonic profile. Their overtones shimmer sweetly. Feedback is rich and musical. They are unbelievably dynamic, yielding excellent and endlessly varied tones throughout the range of the guitar's volume knob. *Mmm.*

Not all vintage fuzz pedals use germanium: Mosrite Fuzzrites, Jordan Bosstones, Foxx Tone Machines, and Electro-Harmonix Big Muffs are just a few examples of great vintage fuzzes that used silicon transistors. But the Maestro Fuzz-Tone, the Dallas Rangemaster, the original Tone Benders, and early Fuzz Faces all used germanium.

Germanium Transistors: The Downside

Germanium components are usually available only from specialized distributors, who inevitably sell them for many times the cost of their silicon equivalents. (You can find a list of reliable vendors on the project page at tonefiend.com.)

- There's much variation in quality from germanium transistor to germanium transistor.
- They're noisy.
- Their tone changes with the air temperature.
- The vast majority of surviving germanium transistors are of the PNP variety, which means they're engineered for positive-ground circuits, which were common in the '60s, but nearly non-existent today. You can't use a pedal with PNP transistors with a conventional negative-ground power supply unless you jigger with the schematic — which is exactly what we do here.
- You *can* find NPN, i.e., negative-ground, germanium transistors, but they're rarer and more expensive, and you generally have fewer models to choose from. If a) you dig the germanium sound, and b) might want to build more germanium-powered pedals in the future, I suggest getting into the PNP habit.

Working with PNP Transistors

Unlike the NPN transistors we've used in previous projects, PNP-type transistors are designed to work in positive ground circuits. That creates two issues:

- You can't power a positive-ground effect with a contemporary negative-ground power supply (though you *can* use a 9-volt battery).
- Even with a compatible power supply, you swap PNPs for NPNs (and vice-versa) without altering the schematic in other ways.

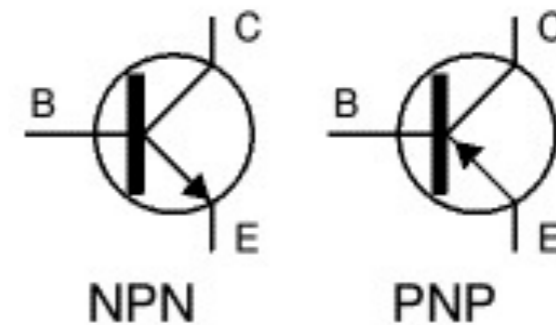

NPN and PNP transistors have separate schematic symbols.

The Original Schematic

Here's something pretty close to the original Rangemaster schematic.

If you want to build a relatively faithful replica, work from this schematic, omit the DC adapter, and power it via battery only.

You can try this with any PNP germanium transistor. But the relatively common AC-128 will sound great here.

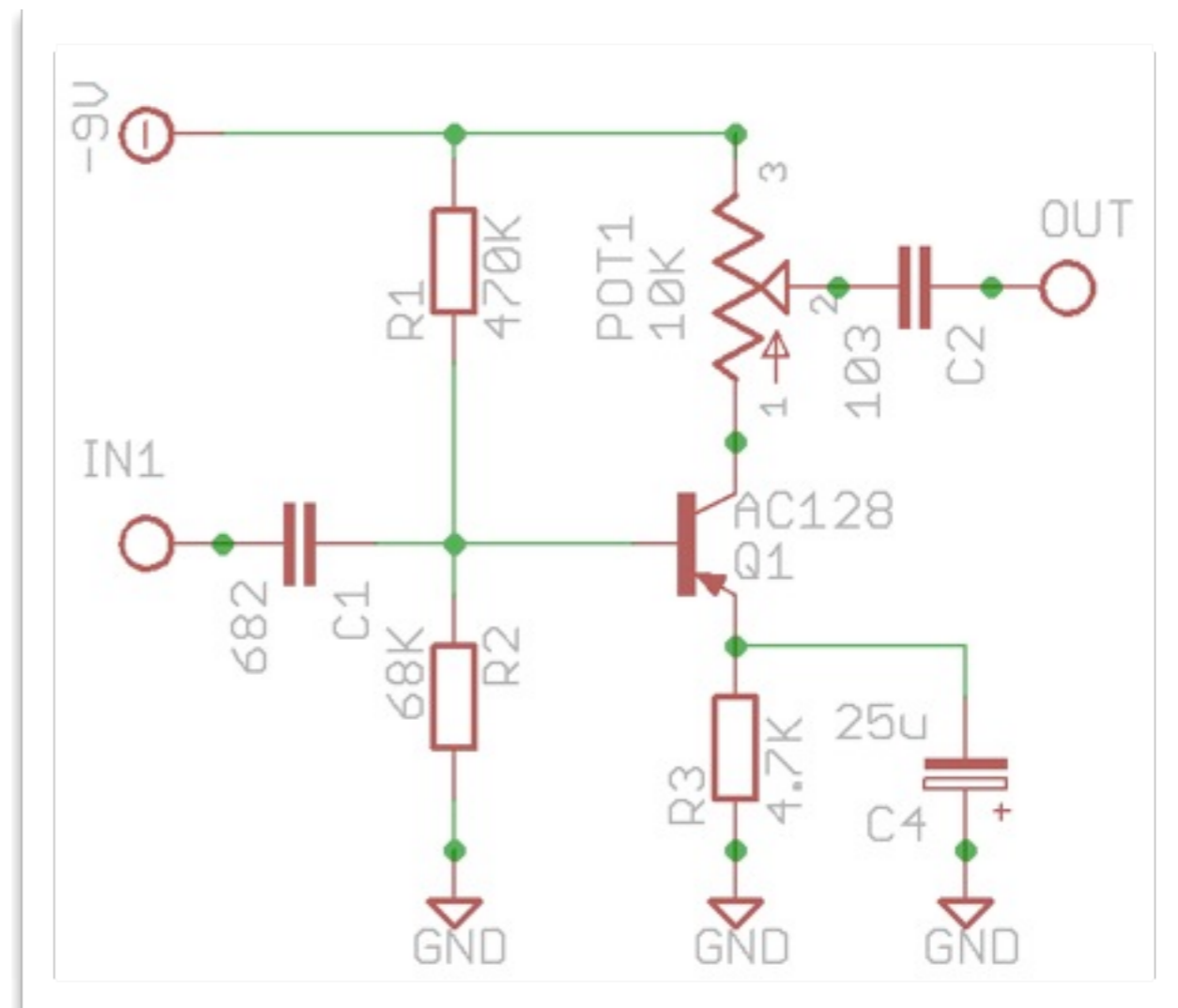

An NPN Version

Here's a modified version you can build if you have an NPN-type germanium transistor. This works fine with a conventional negative-ground power supply.

Note that the orientation of the 25u electrolytic cap is reversed relative to the PNP version.

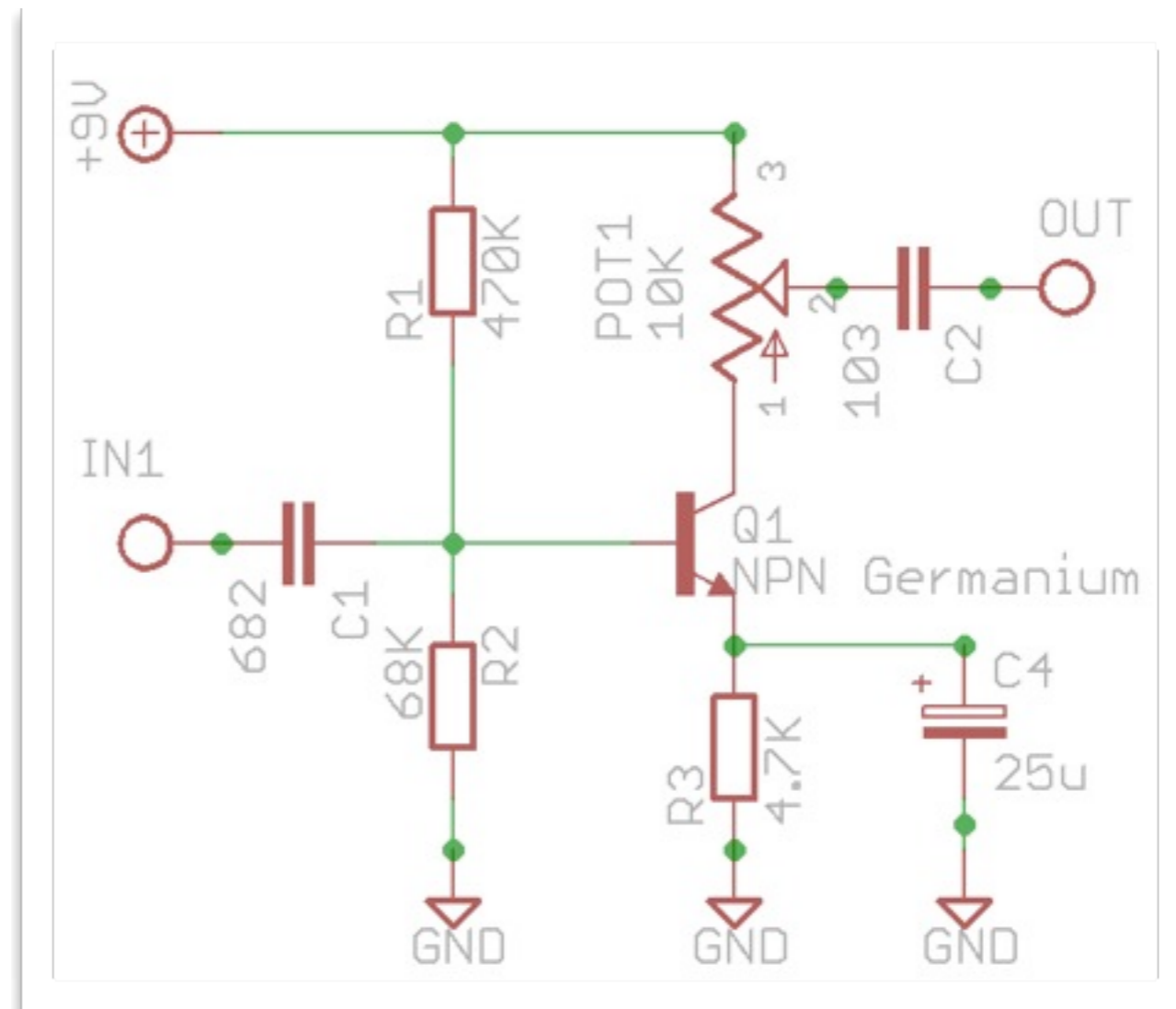

Our Project Schematic (basic version)

Here's the version we'll work with in the following pages.

To deploy a PNP transistor with a negative-ground power supply, we've reversed *all* the positive and negative connections in the circuit. The schematic is pretty much "upside down" relative to the original.

Other changes:

- I've swapped the 25u for a more common 22u, which has negligible sonic impact.
- The A50K pot provides a wider variety of sounds (including all the original ones).
- I prefer a 3.9K value for R3, but by all means, try the original 4.7K if you like.

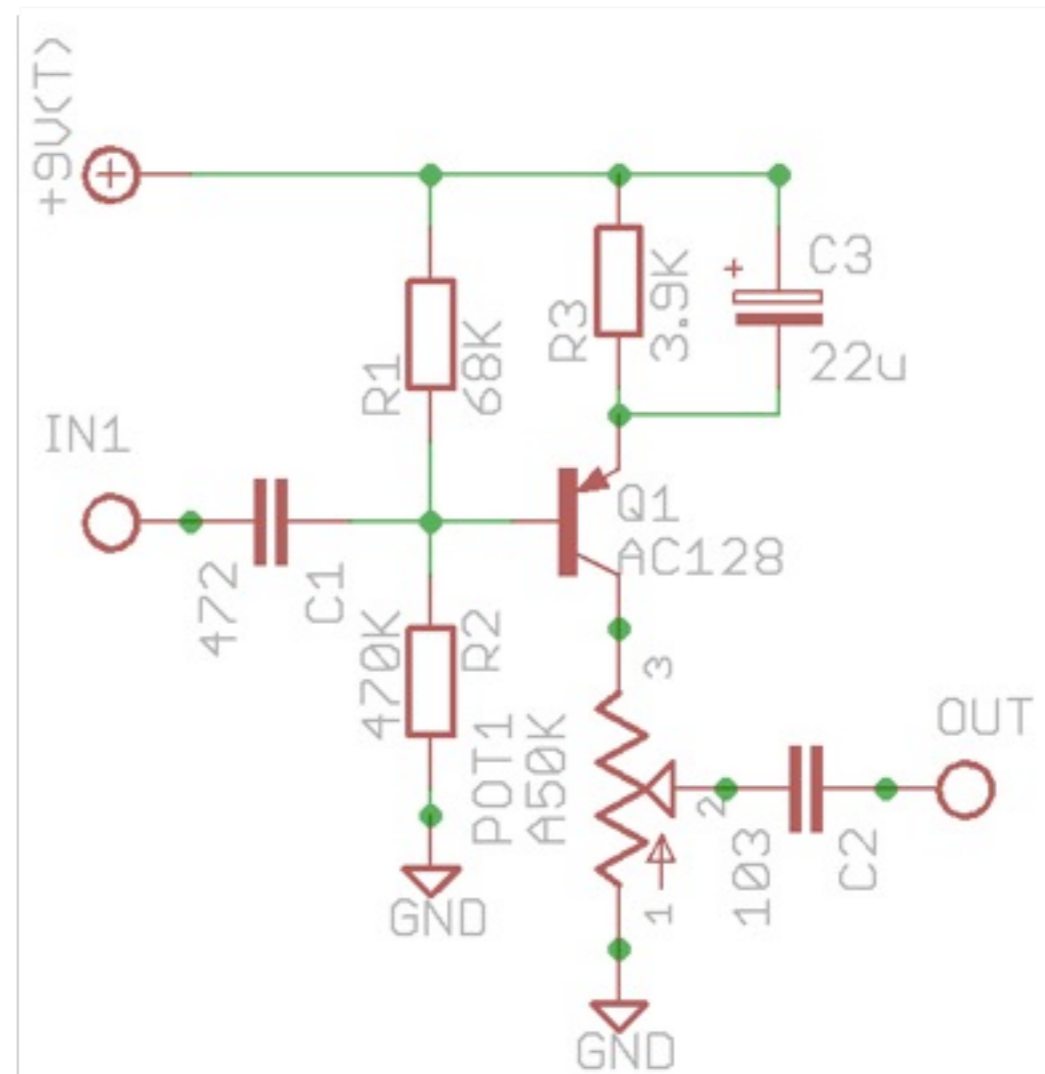

The Transistor Pinout

Here's the pinout for the AC128 transistor I used here. It's the most common pinout for PNP germanium transistors.

If it doesn't work, try swapping the collector and emitter wires. If that doesn't work, find the pinout for your transistor online — just Google the part name plus “pinout.” And make sure you're not using an NPN-type transistor.

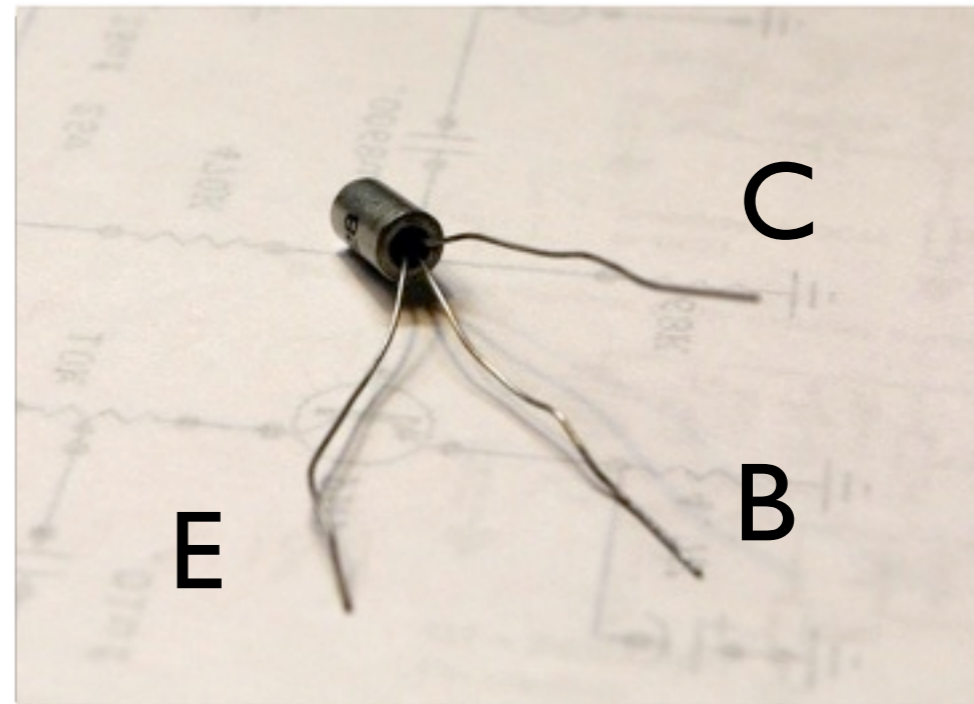

Let's Get Started!

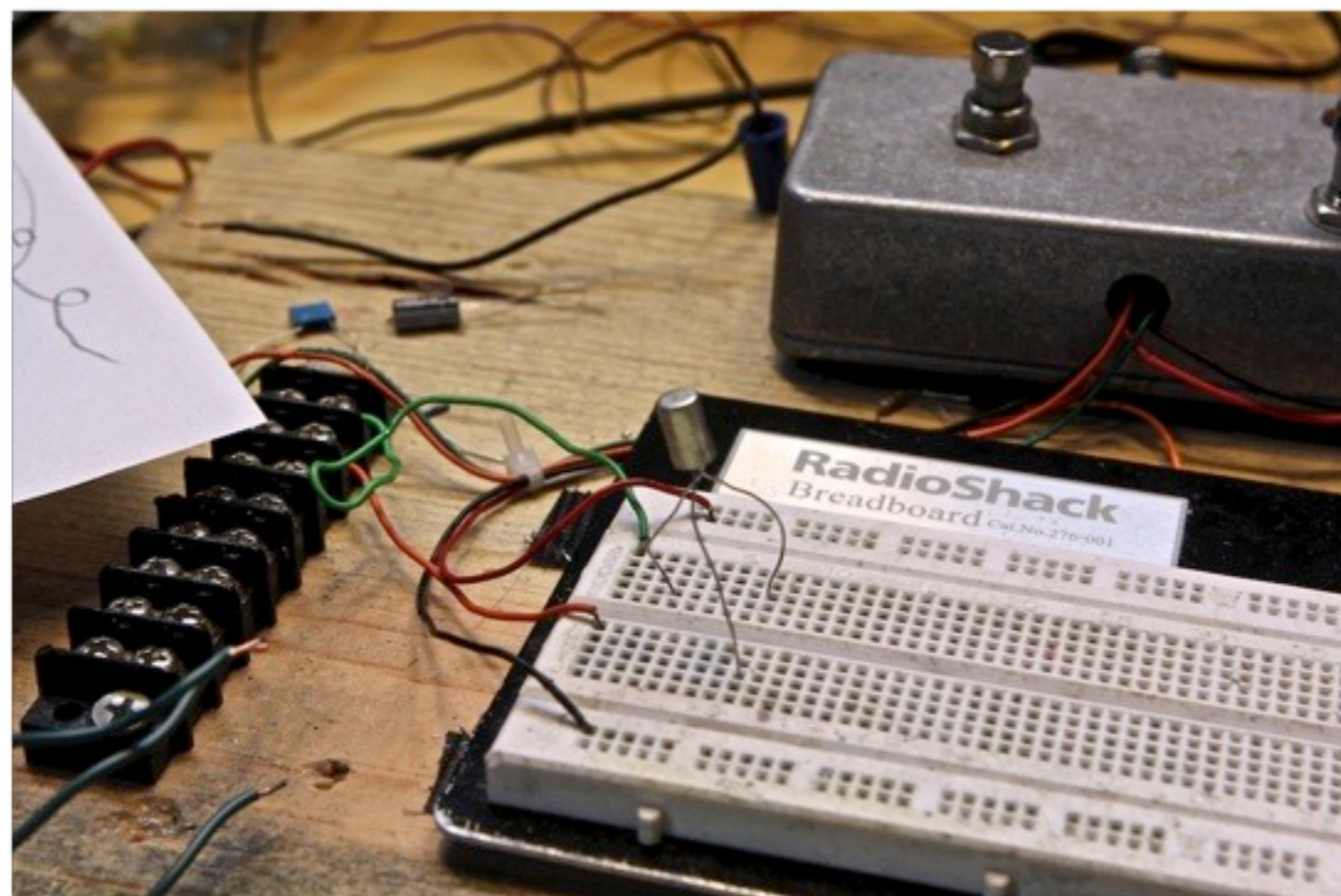

Connect the power, ground, and audio in/out wires to your breadboard (as detailed in Project #1).

Plug the transistor's three wires into three different busses, with the base (here, the middle wire) oriented toward the input.

Connect the Transistor's Base

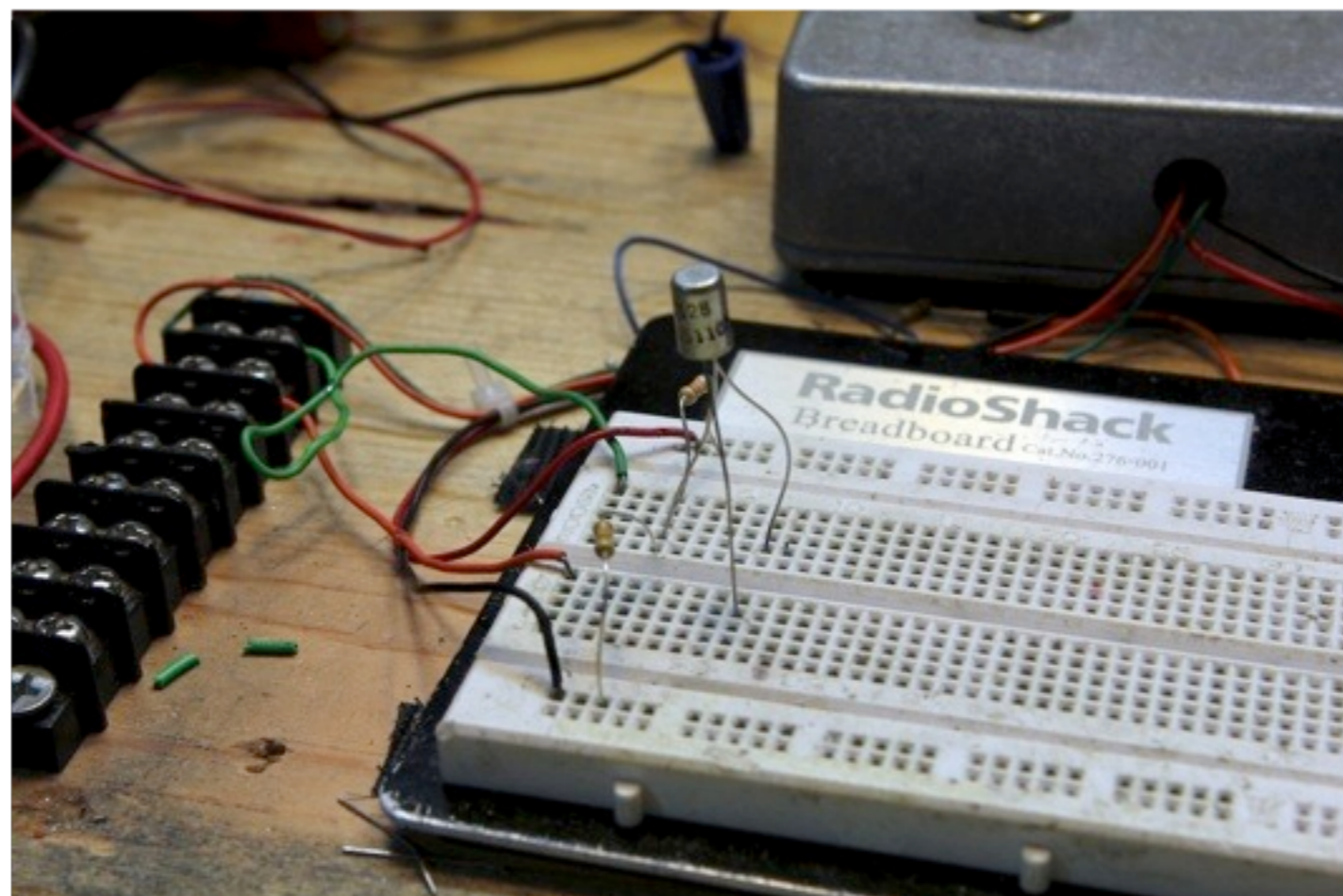

Connect the transistor's base to the power bus using a 68K resistor. Connect the base to ground using a 470K resistor. (In other words, you'll have three wires on the same bus.)

Connect the Collector

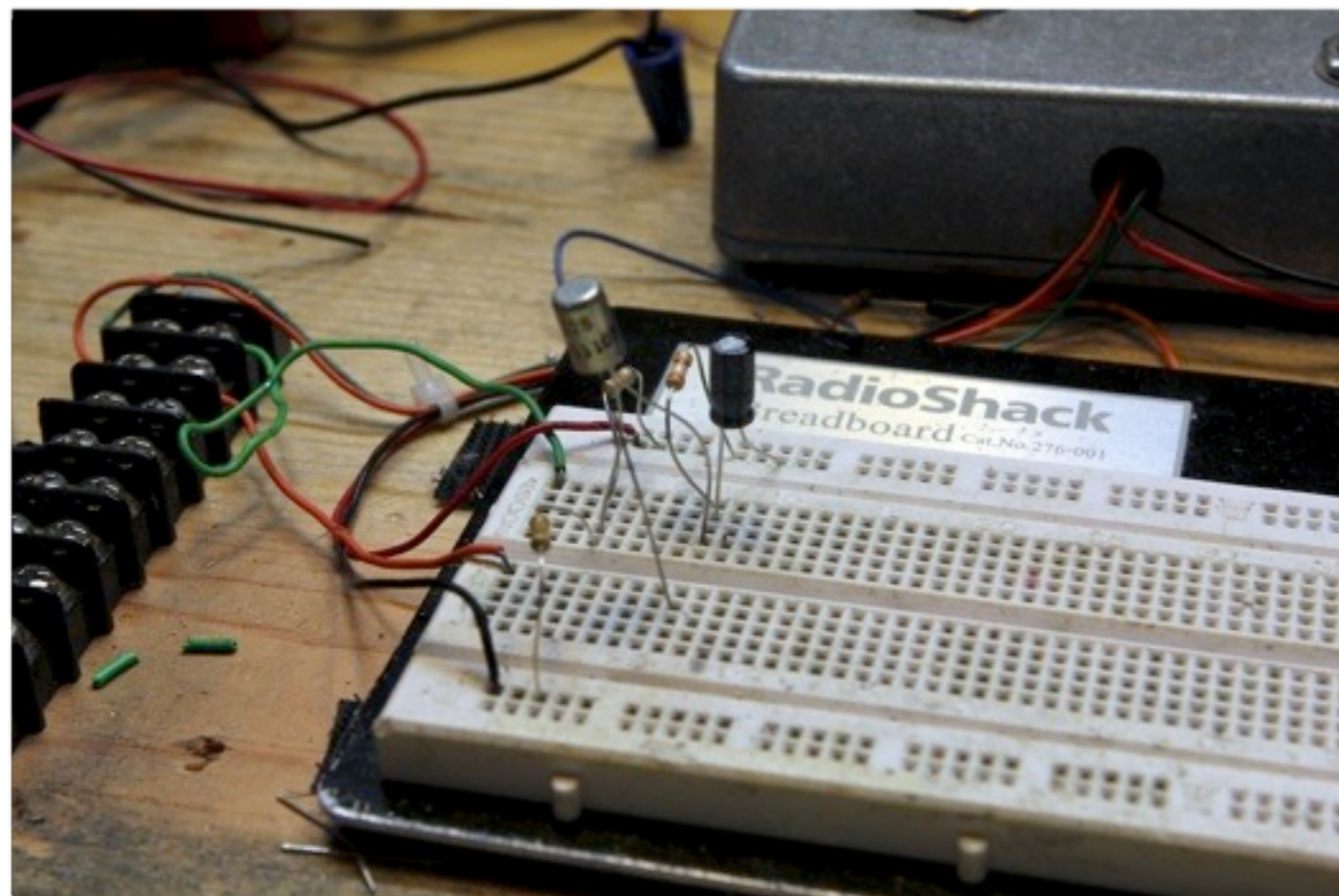

Connect the transistor collector to the power bus using a 3.9K resistor. Connect the same two points with a 22uF electrolytic capacitor. (Again, you'll now have three wires on the same bus.) As usual, the longer leg of the electrolytic cap connects to the power bus.

Wire Up Your Pots

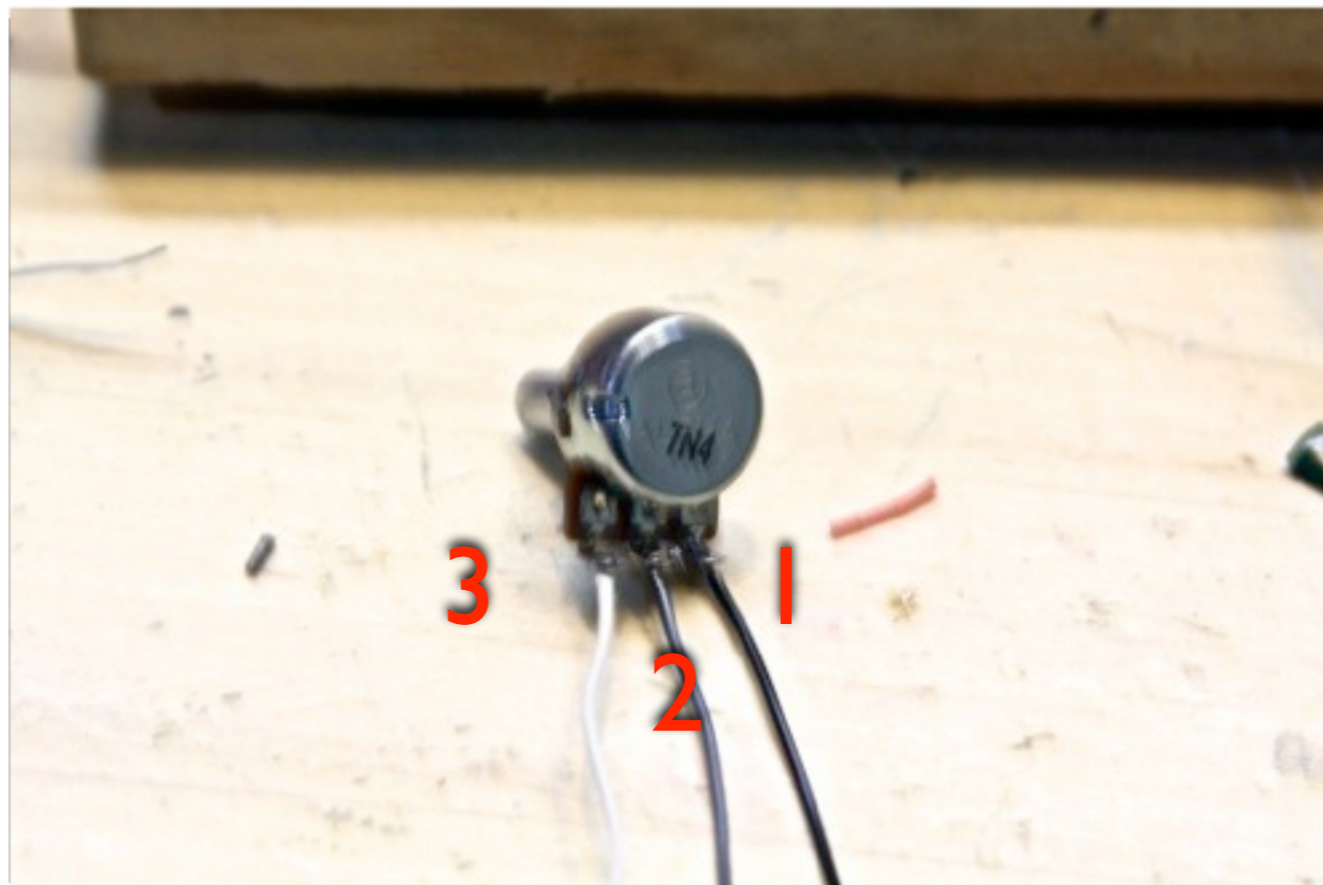

Solder three short wires to the lugs of an A50K pot. (You can also use an A10K, A20K, or A25K, but the A50K affords the widest range of tones.) Remember that, when viewed from the back like this, the pot's lugs are numbered as above.

While you're at it, wire up a B100K pot in the same way. (or use the alternate wiring shown on page 30). We'll use this pot later.

Connect the Emitter to Ground

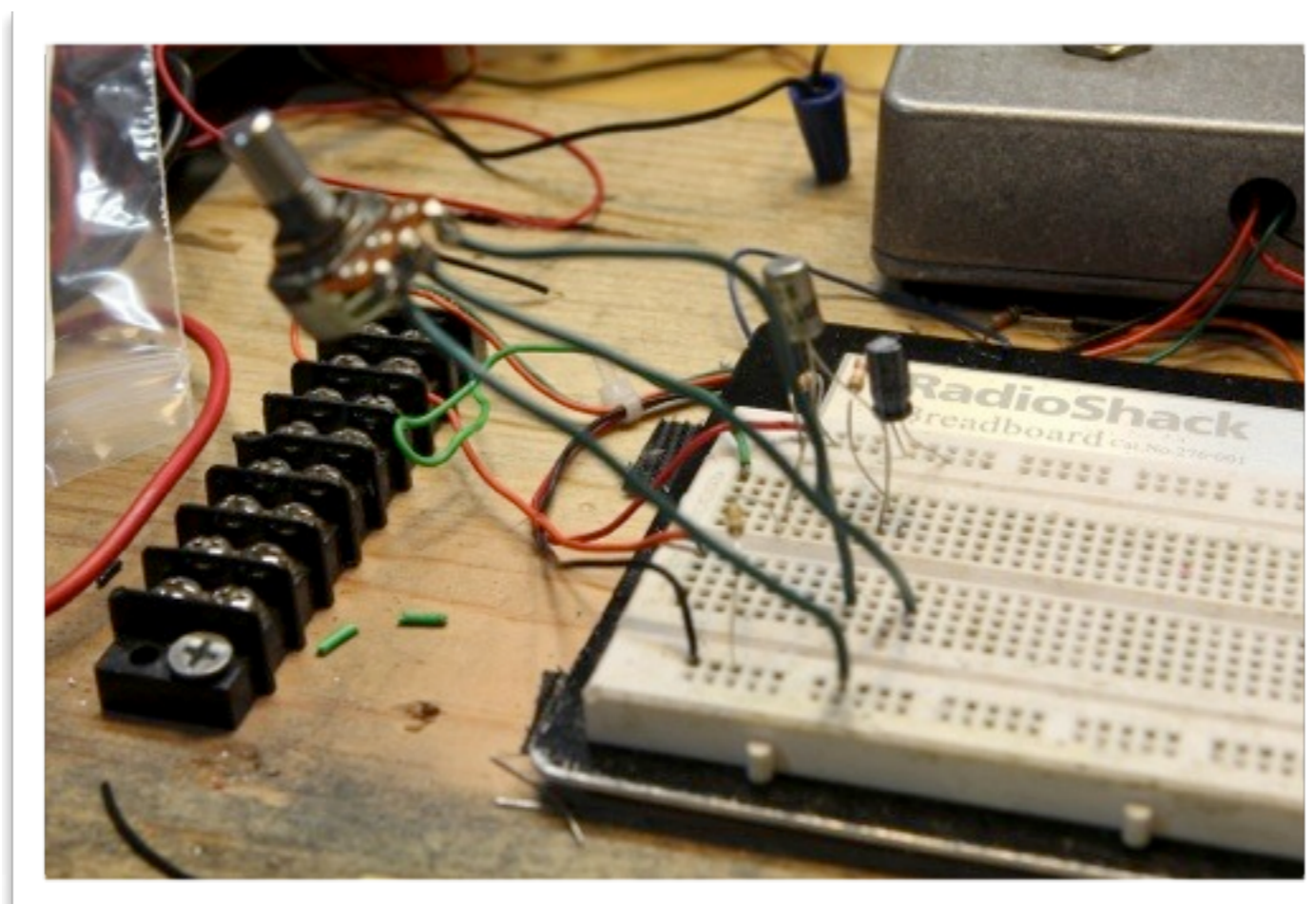

Connect lug 3 of the A50K pot to the transistor's emitter. Connect lug 1 to ground. Place the wire from lug 2 into an empty bus.

Connect the Input to the Base

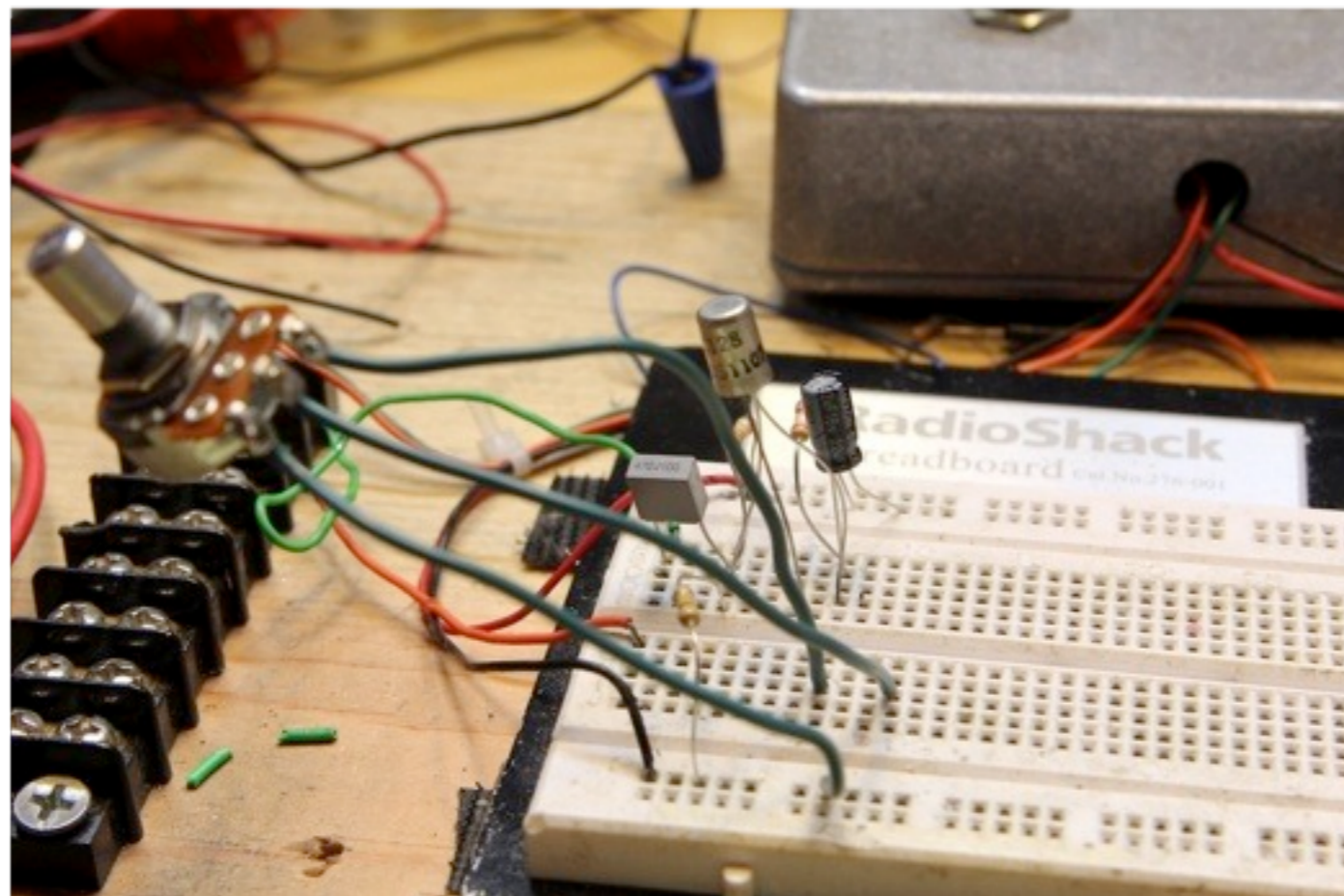

Use a 472 capacitor (also called a .0047 μ F or a 4.7n) to connect your input wire to the collector base. The base will now share a bus with three other wires.

Connect to the Output

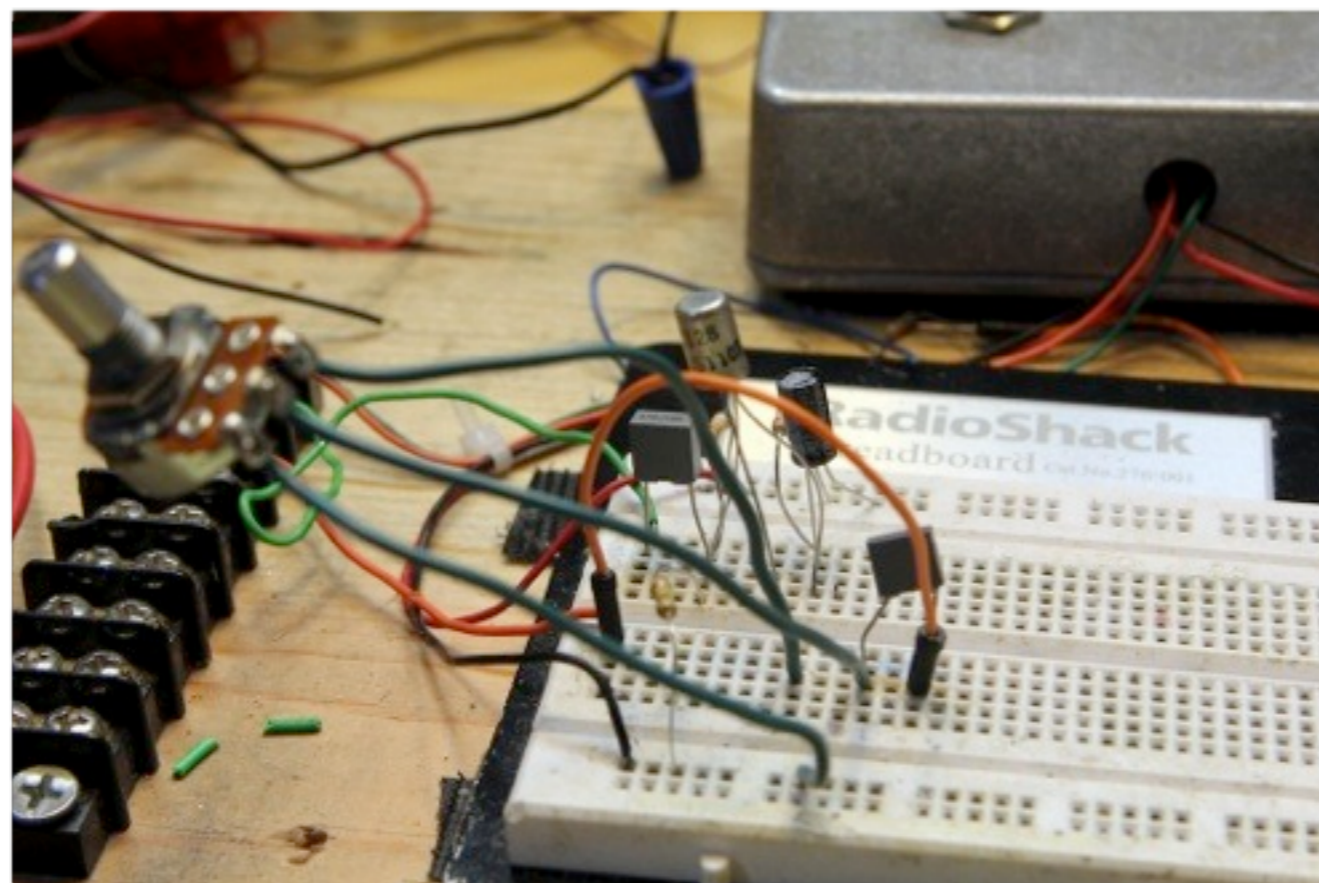

Connect one leg of a 103 capacitor (also know as a .010uF and a 10n) to the A50K pot's lug 2 wire. Connect the other leg of the cap to your output. (I used an orange jumper wire for this connection.)

About that Input Cap . . .

Turn up the A50K pot. You should now hear the pedal in action. The tone will be a bit trebly, with some of the resonant quality of a fixed wah pedal. Right now you're pretty close to the tone of an original Rangemaster.

If the gain knob works opposite from how you want it, just reverse the wires from lugs 1 and 3. (In fact, you can do this anytime you want to reverse the action of a pot.)

The effect isn't so much boosting treble as filtering out bass, and boosting what's left.

The 472 capacitor (C1) is the filtering element. If you substitute a smaller-value cap, the tone gets even brighter and tinnier. If you use a larger value, less bass is removed. The tone not only gets bassier, but also louder and more distorted, because there's more overall signal to drive the transistor.

Let's try it out.

Substitute a Larger Input Cap

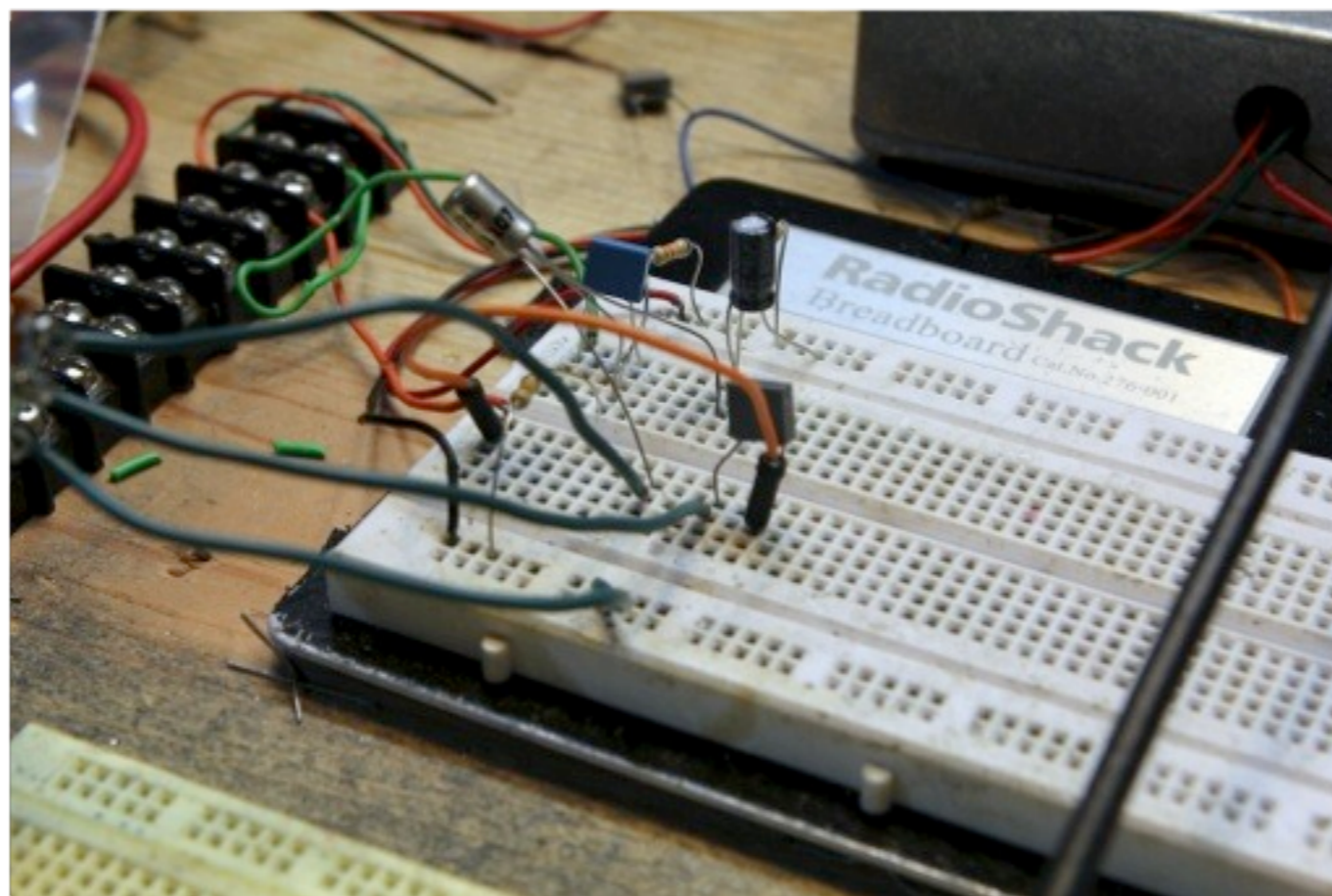

Replace the 472 input cap with the larger 104. The effect should become a much more loud, deep, and distorted. (Don't be fooled by the physical cap size — the small blue cap in the pic above is actually of larger value than the fat gray one in the previous pics.)

Congrats! You're a Musicologist!

You've just discovered an important link in the history of rock guitar. The emergence of heavy, power-rock guitar has a lot to do with Rangemasters modded with larger input caps for deeper, more distorted tones.

Metal starts here.

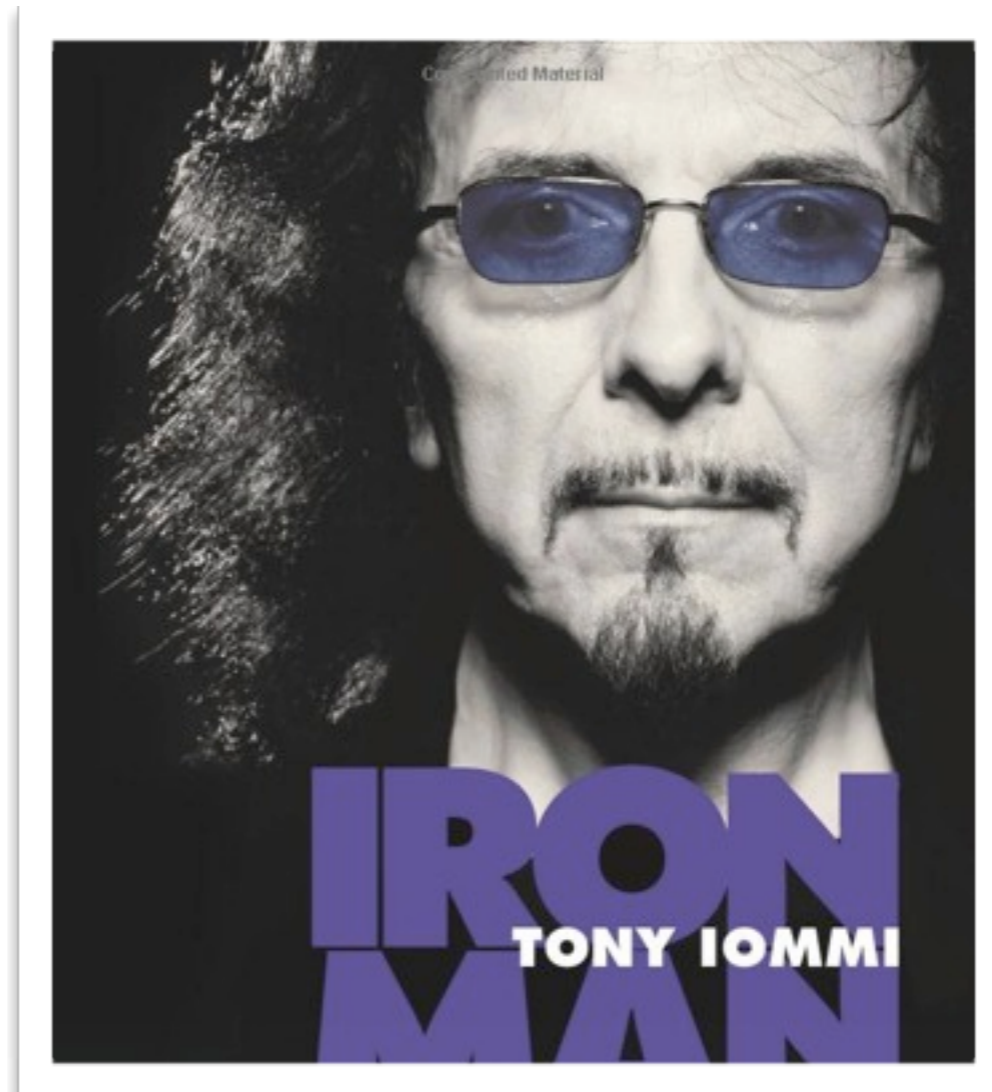

Input Cap Options

You can try different input caps here. The most common values between the 472 and 104 are (in ascending order), 682, 103, 223, 473, and 683. Maybe you'll find one that's perfect for you. (You could also go larger than 104 with a 224 or 474, but in my experience, that extra bass just makes everything sloppy.)

Or why not make it adjustable? You could switch between two favorite values with a SPDT switch, or many values using a rotary switch.

Better yet: let's add another pot to fade between the thin, trebly 472 and the beefy 104.

Add a Second Input Cap

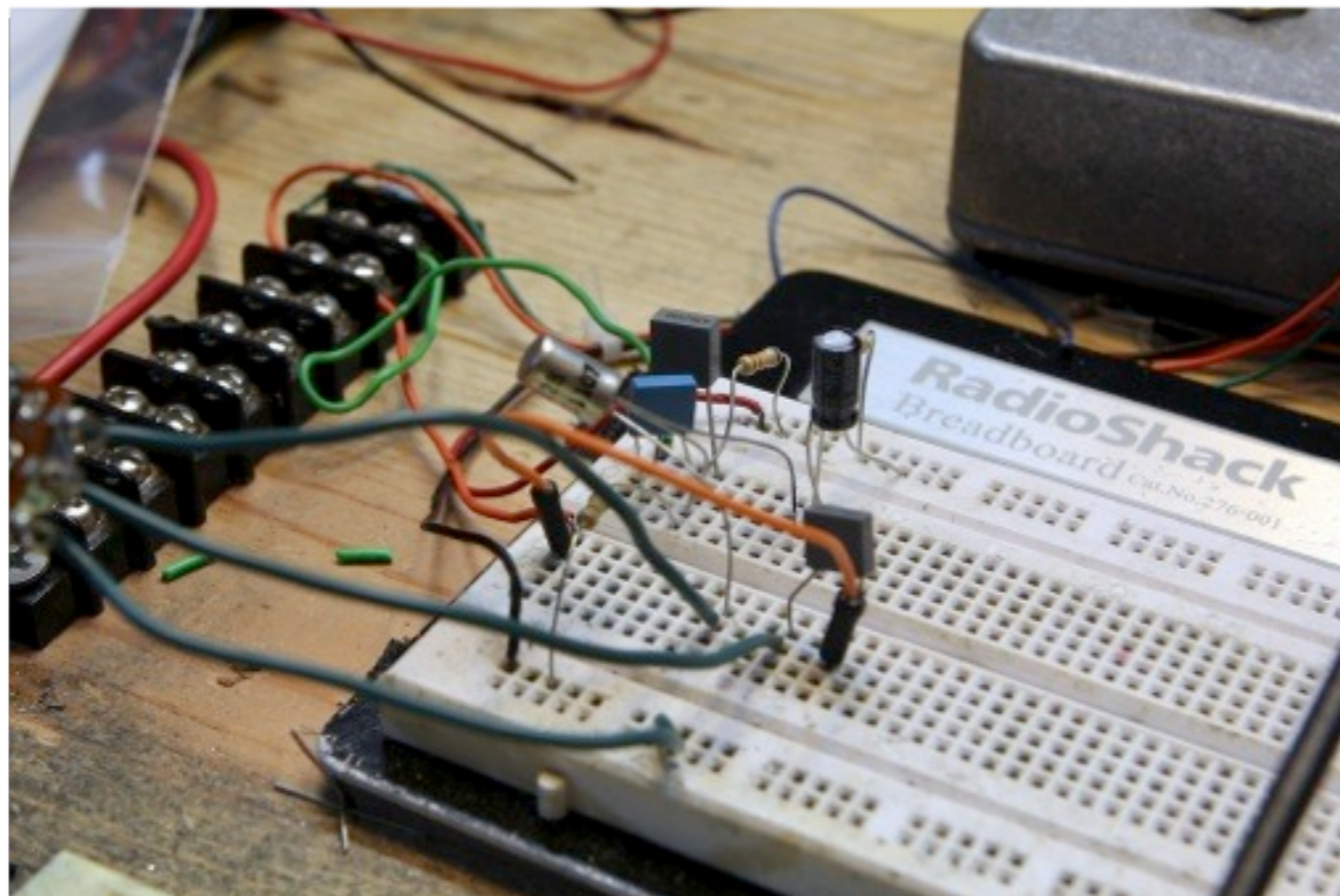

Put the 472 cap back as at was on page 16. Place one leg of the 104 cap into the same bus as the transistor base and the rightmost leg of the 472. (Yes, you'll now have five wires in the same bus, and you may have to reorganize them.) Place the leftmost leg of the 104 in an empty bus near the input.

Add a Tone Pot

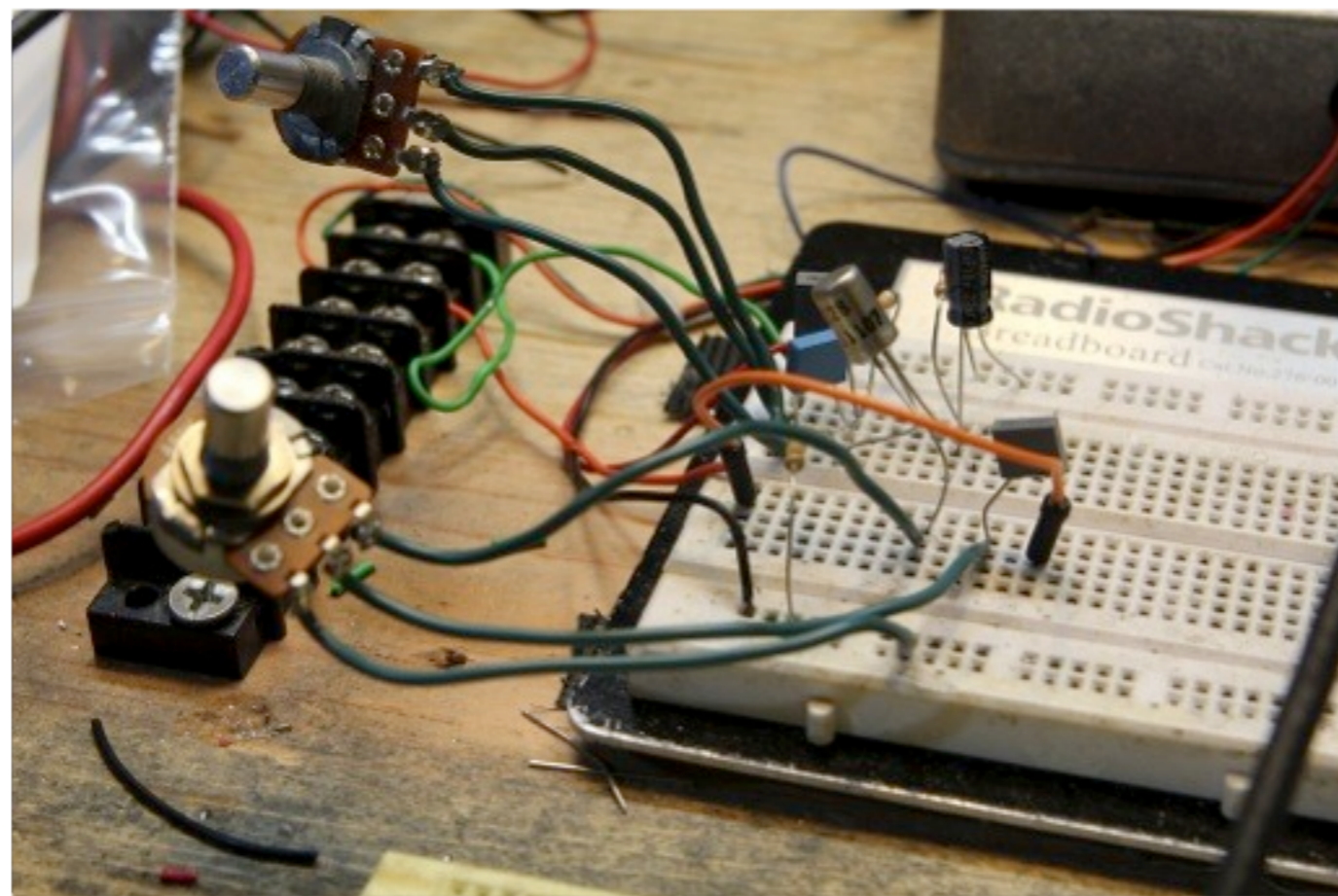

Place the wires from lugs 2 and 3 of the B100K pot you prepared on page 13 in the same bus as your input wire. Place the wire from lug 1 on the same bus as the leftmost leg of the 104 cap.

Now the distortion tone should thin out as you advance the pot. If you'd like this control to work the other way around, just swap the wires from lugs 1 and 3. Your final pedal will sound like this.

Our Final Schematic

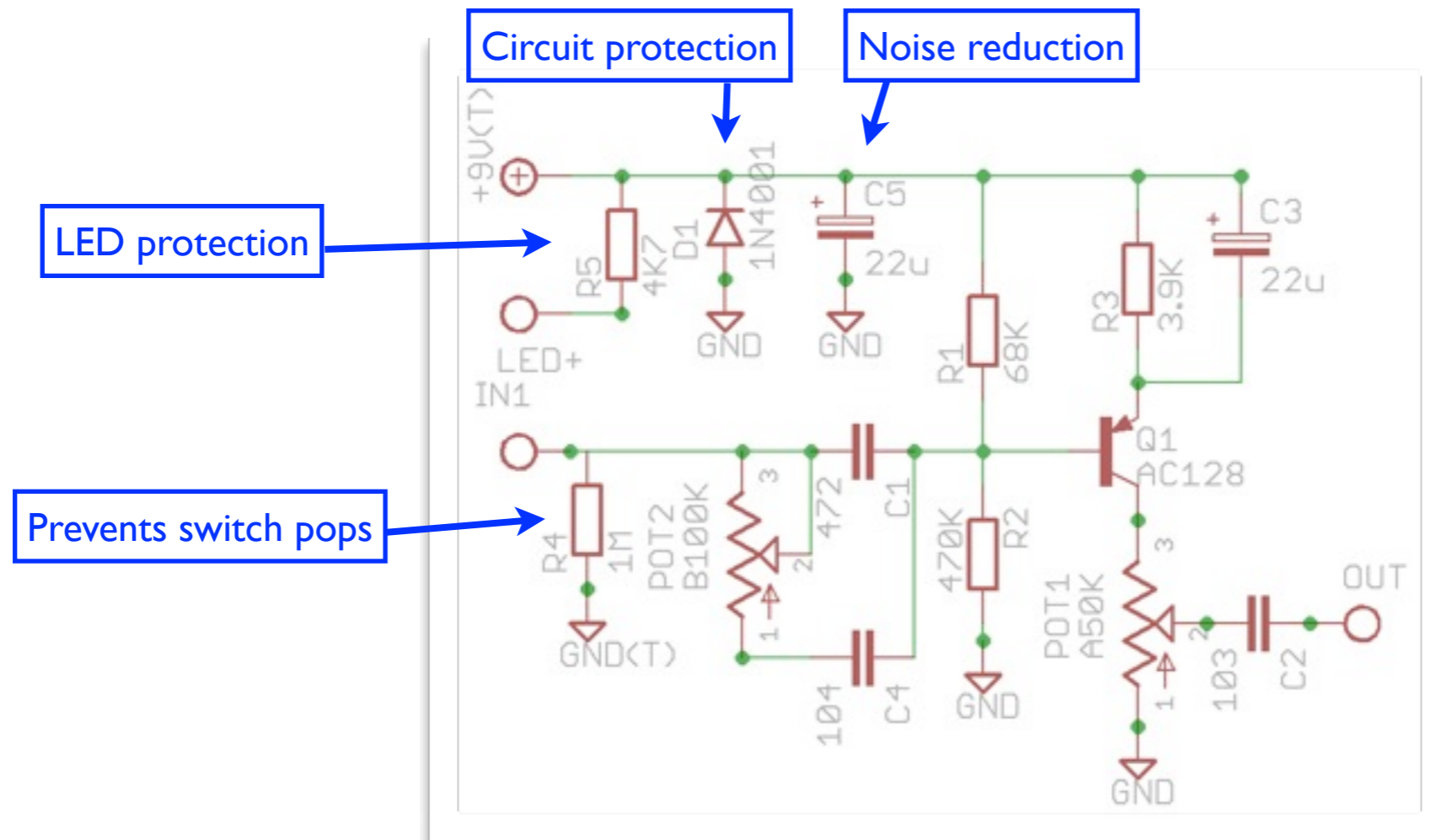

Before we move on to perboard, check out this expanded schematic. It includes the input cap control we just added, plus the usual extras that don't effect the tone, but which reduce noise and protect the circuit.

Start Perfboarding!

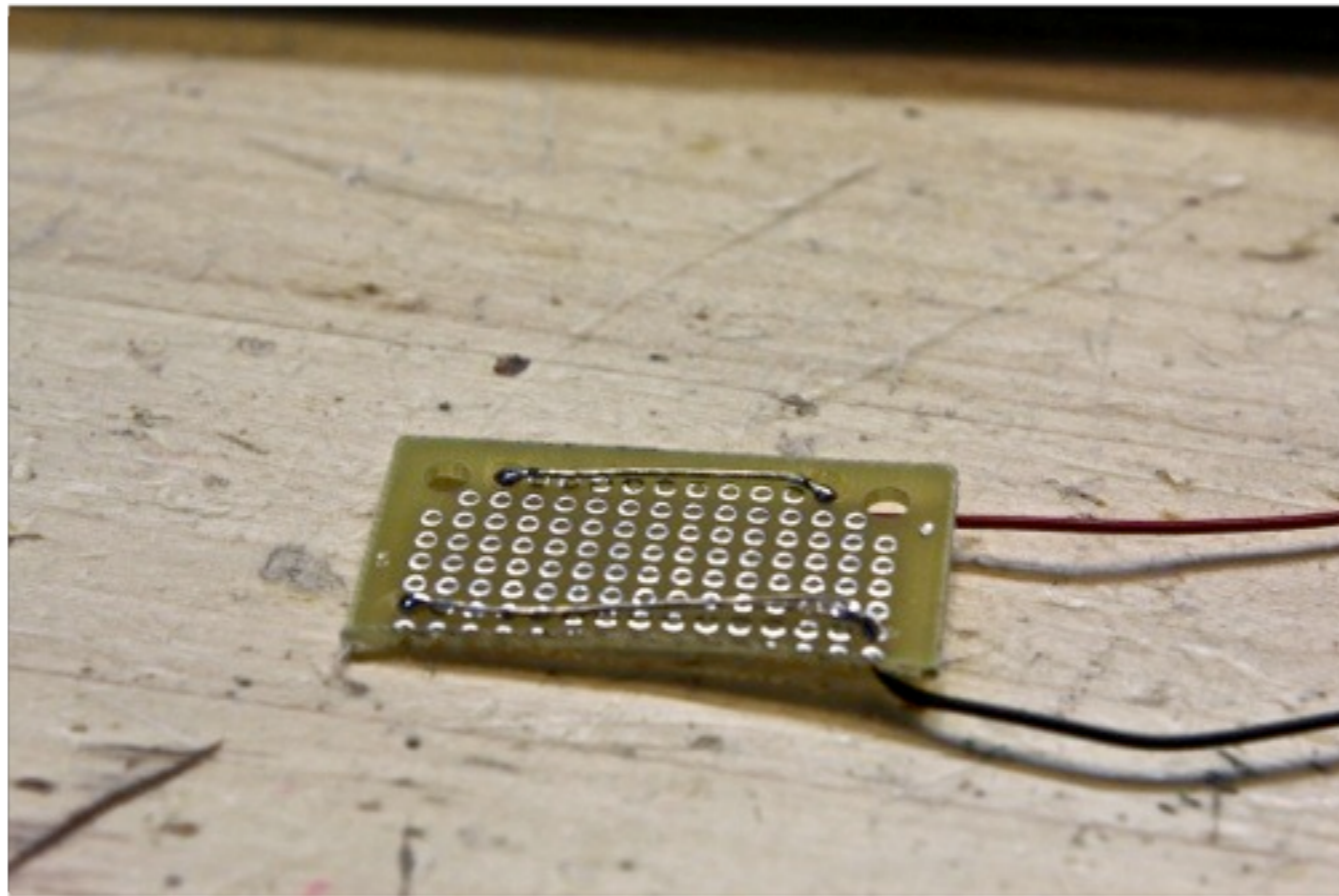

Prepare a piece of perfboard about this size. Strip several inches from a pair of wires and solder them loosely in place for your positive and negative busses.

To Socket or Not to Socket?

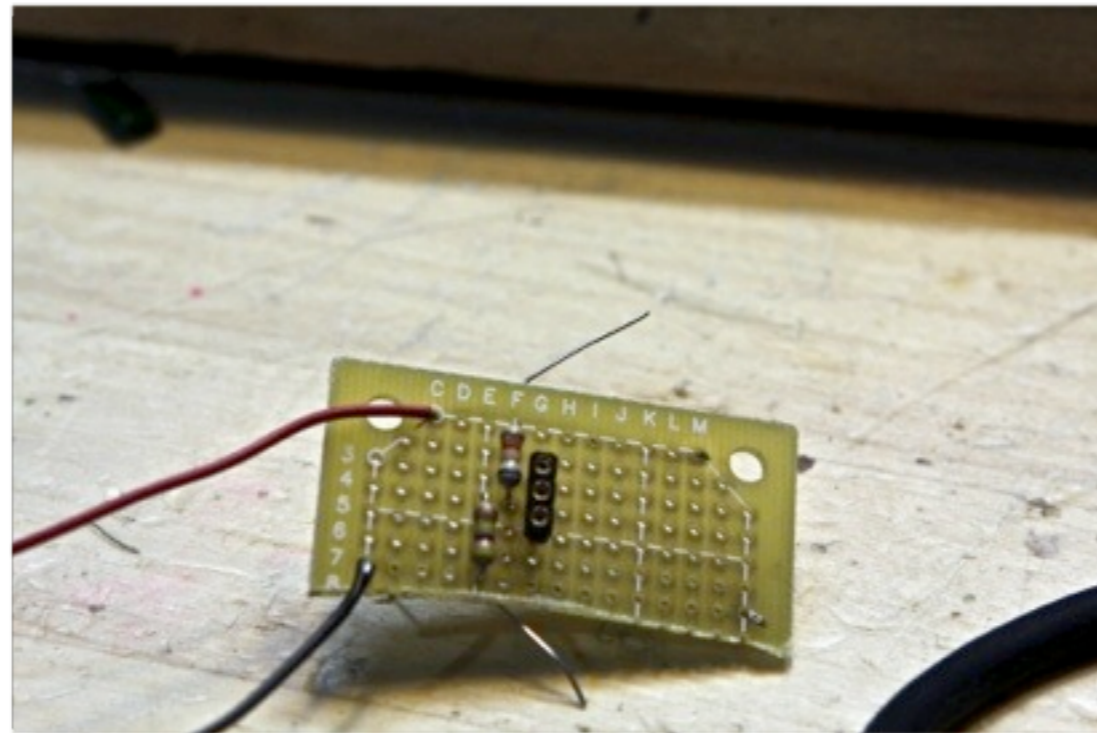

Here I've used a piece of SIP socket to house the transistor. The advantage: You can audition different transistors after the circuit is built, and you don't have to solder the relatively fragile and valuable germanium transistor. It's a major pain unsoldering anything from perfboard if you install it incorrectly!

On the other hand, it's easier to solder the long wire legs of the transistor than the small nubs on the reverse side of the socket material. Your call.

Either way, connect one leg of R1 to the positive bus, one leg of R2 to the negative bus, and one leg of each to the middle pin of the socket or transistor base.

Connect the Dual Input Caps

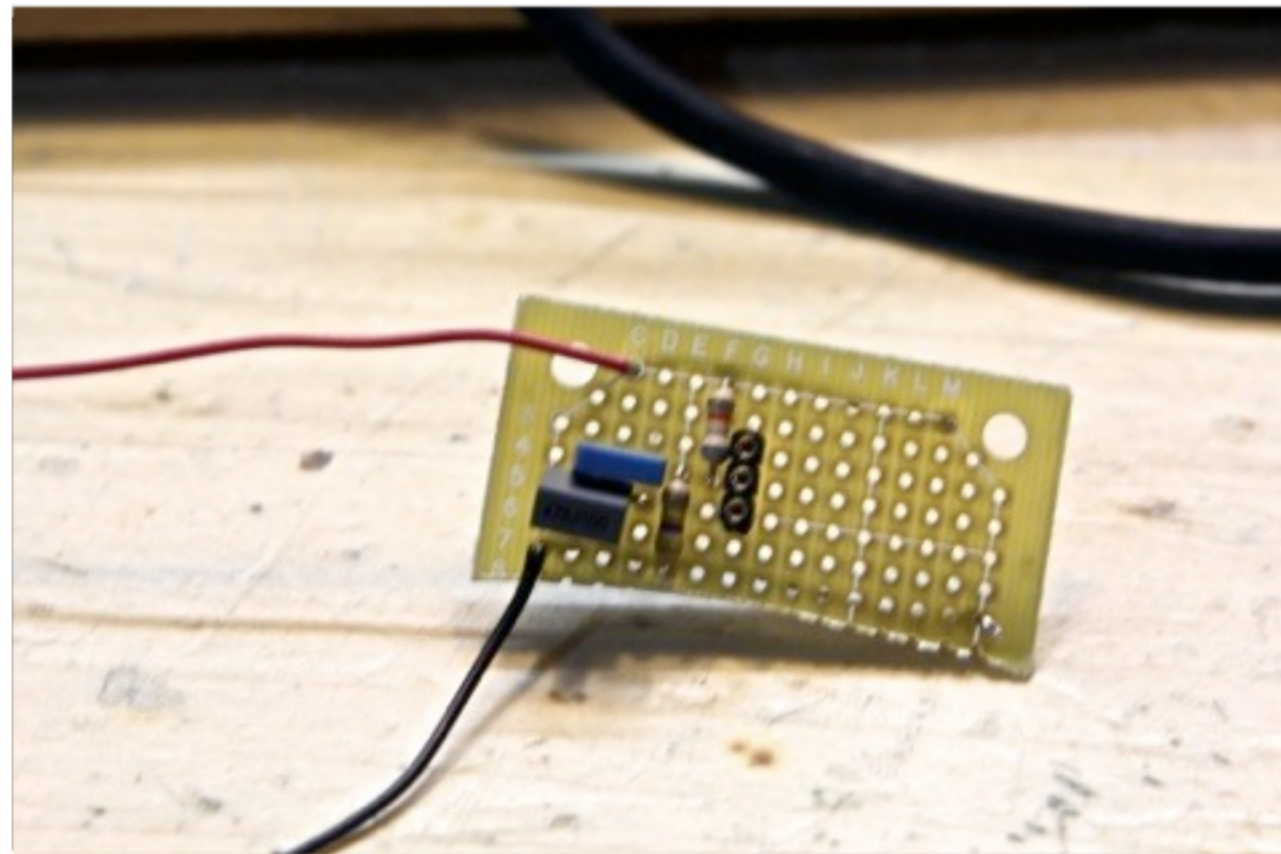

Connect the rightmost legs of C1 and C4 to the middle socket pin. Place the leftmost legs in two adjacent columns as shown.

A Reverse View

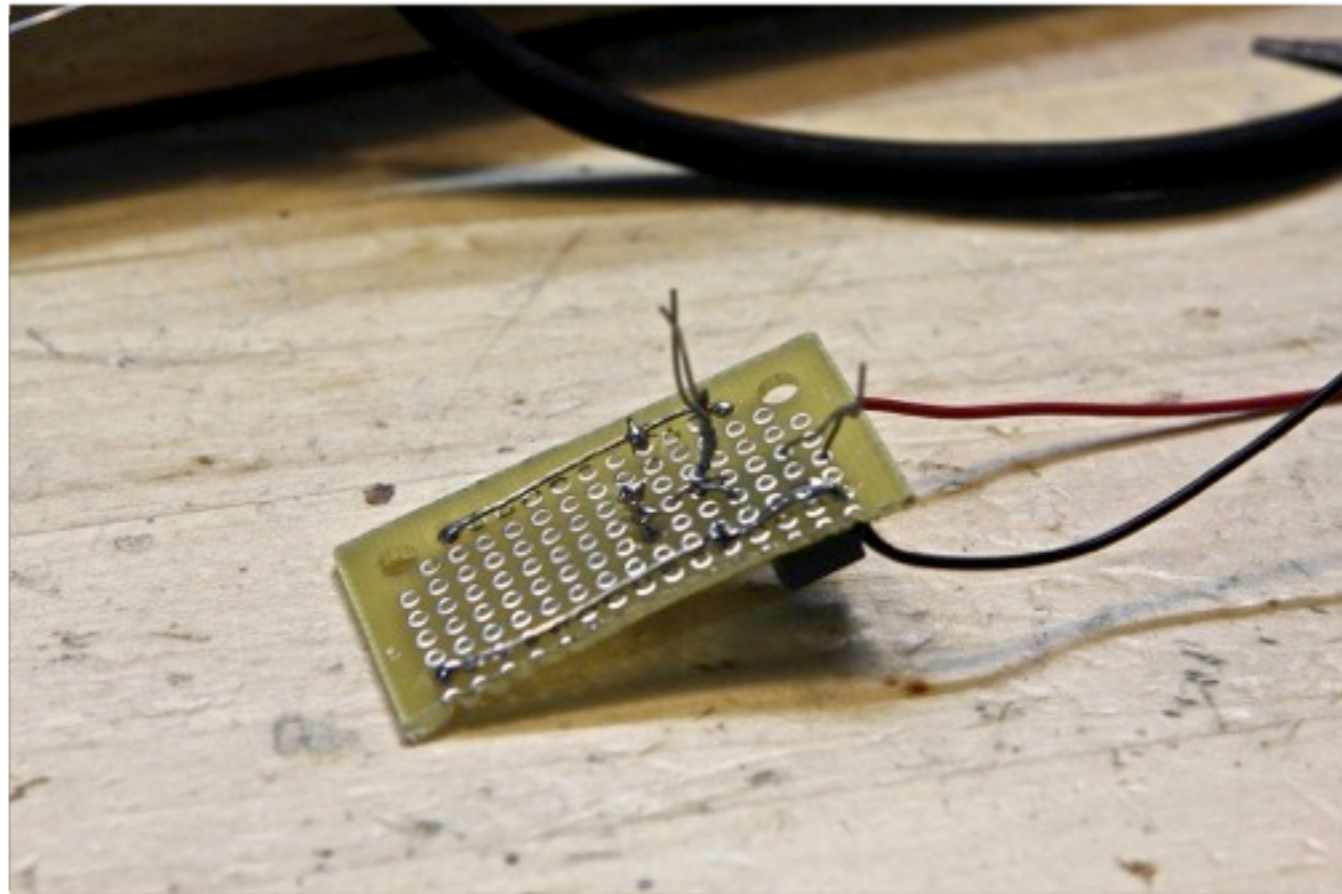

The reverse side of the perfboard will inevitably look like a bloody mess. Just be careful not to let wires touch where they shouldn't. It takes some soldering finesse to connect all those wires to the middle pin of the transistor socket without letting the solder spill over onto the other two socket pins. (This is the part of the project where you'll most regret socketing instead of just soldering in the transistor.)

Add R3, C2, and C3

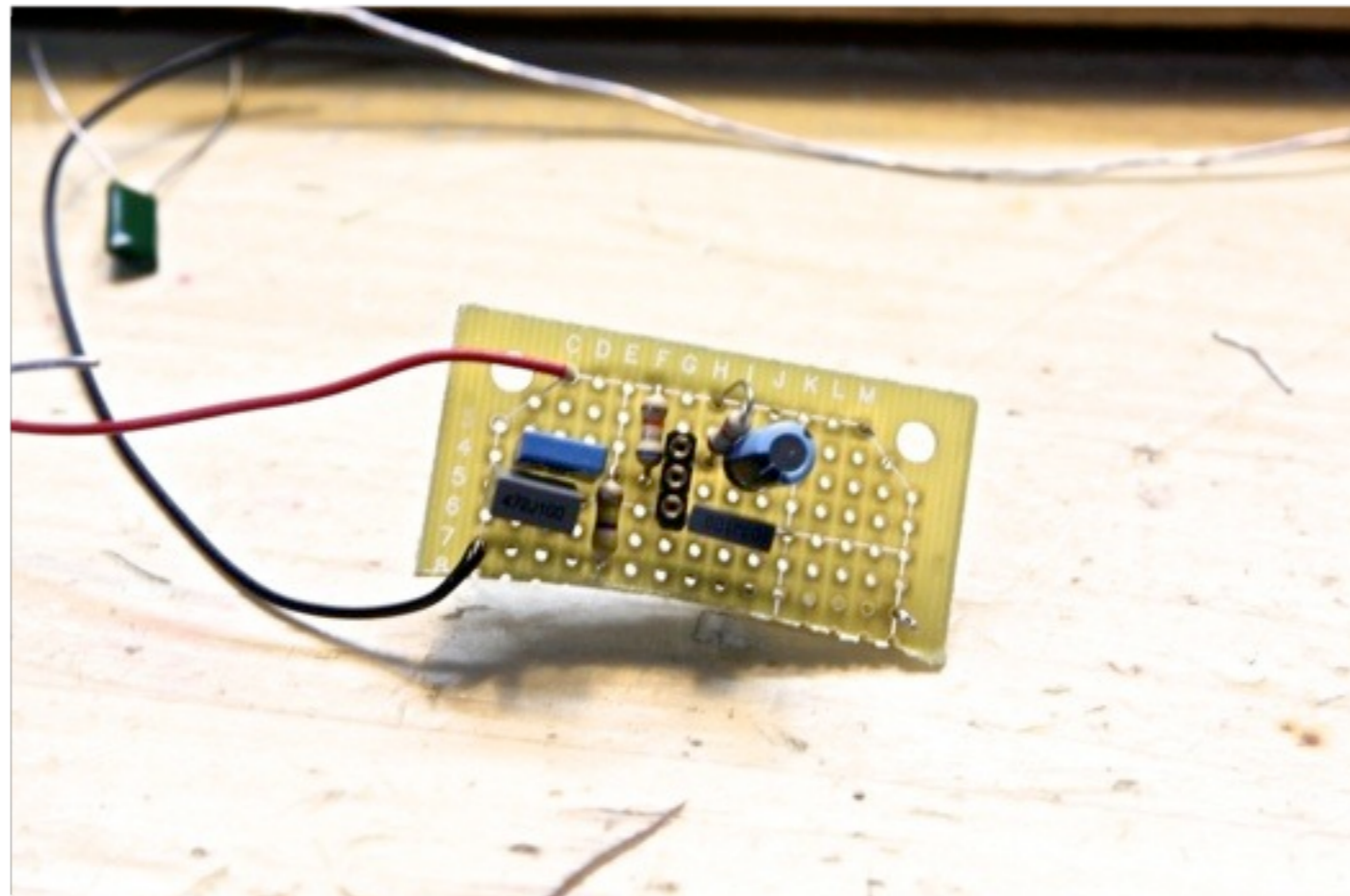

Connect one leg each of R3 and C3 to the positive bus, and the other legs to the topmost transistor socket pin.

Insert C3 as shown, but don't solder it to anything yet.

Add the Gain Pot

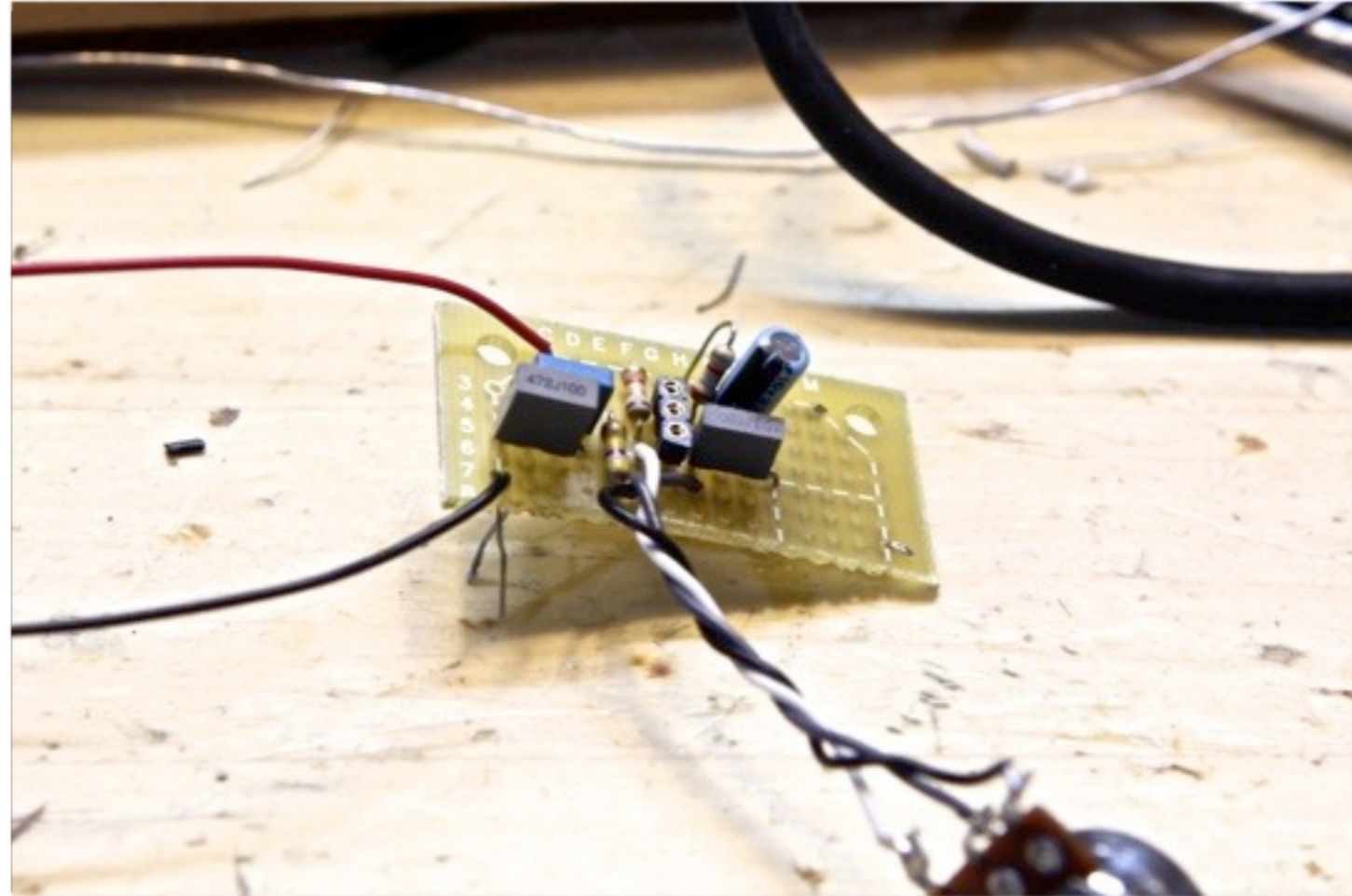

Connect the wire from the A50K pot's lug 3 to the bottom pin of the transistor socket. Connect the wire from lug 1 to ground. Connect the wire from lug 2 to the leftmost leg of C3.

Optional Tone Pot Wiring

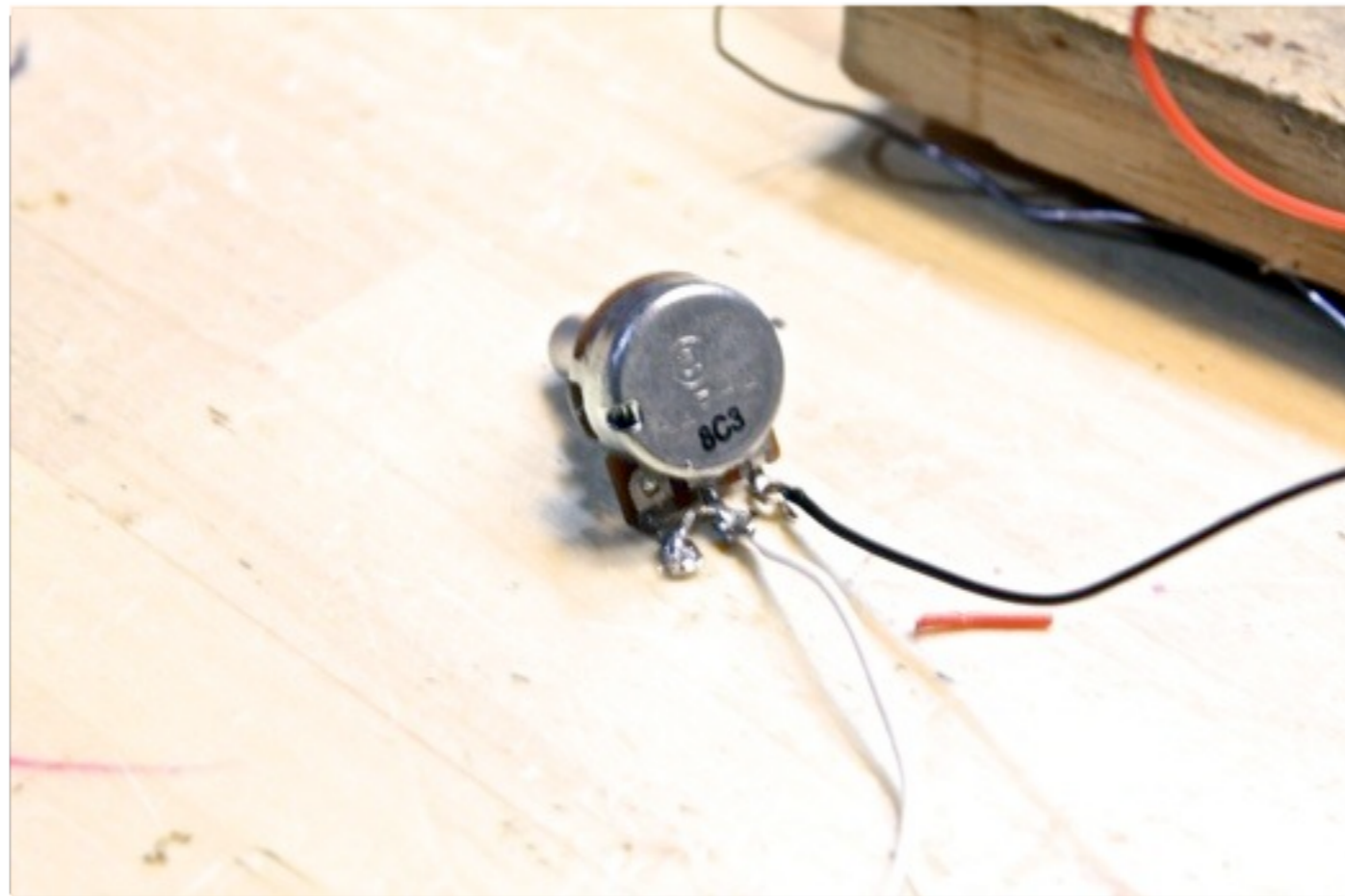

There's another way you can wire the B100K tone pot: Since both lugs 2 and 3 connect to the same destination, you can make the connection right on the pot, threading a stripped length of wire through both lugs and soldering it in place. That way, you only have to place two wires on the crowded perfboard. Again, your call.

Adding the Tone Pot

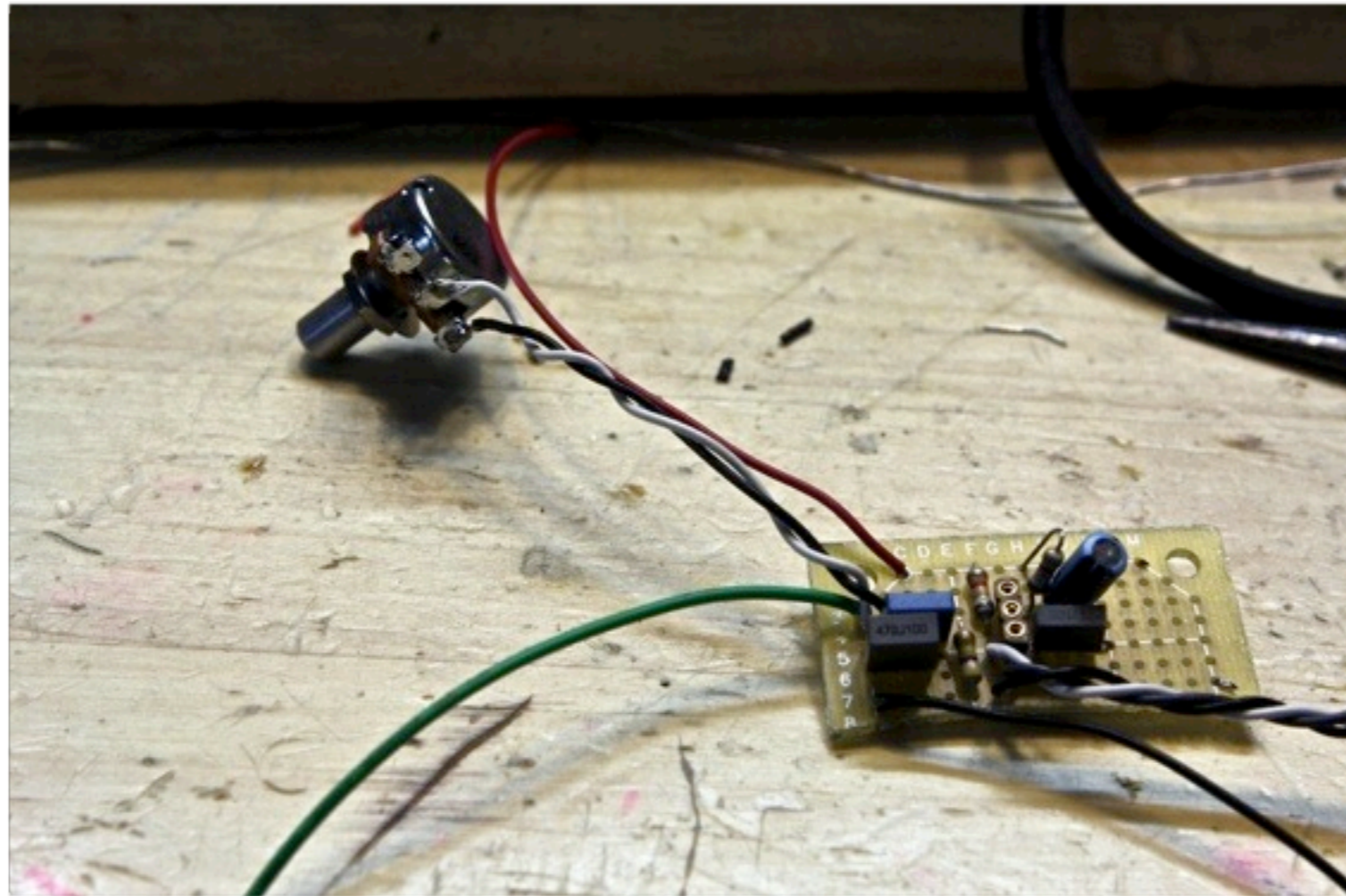

Whether you use two tone pot wires or three, connect lugs 3 and 2 to the leftmost leg of the 104 cap (C4). Attach an input wire to the same location. Connect the lug 1 wire to the leftmost leg of the 473 cap (C1).

Add the Output Wire

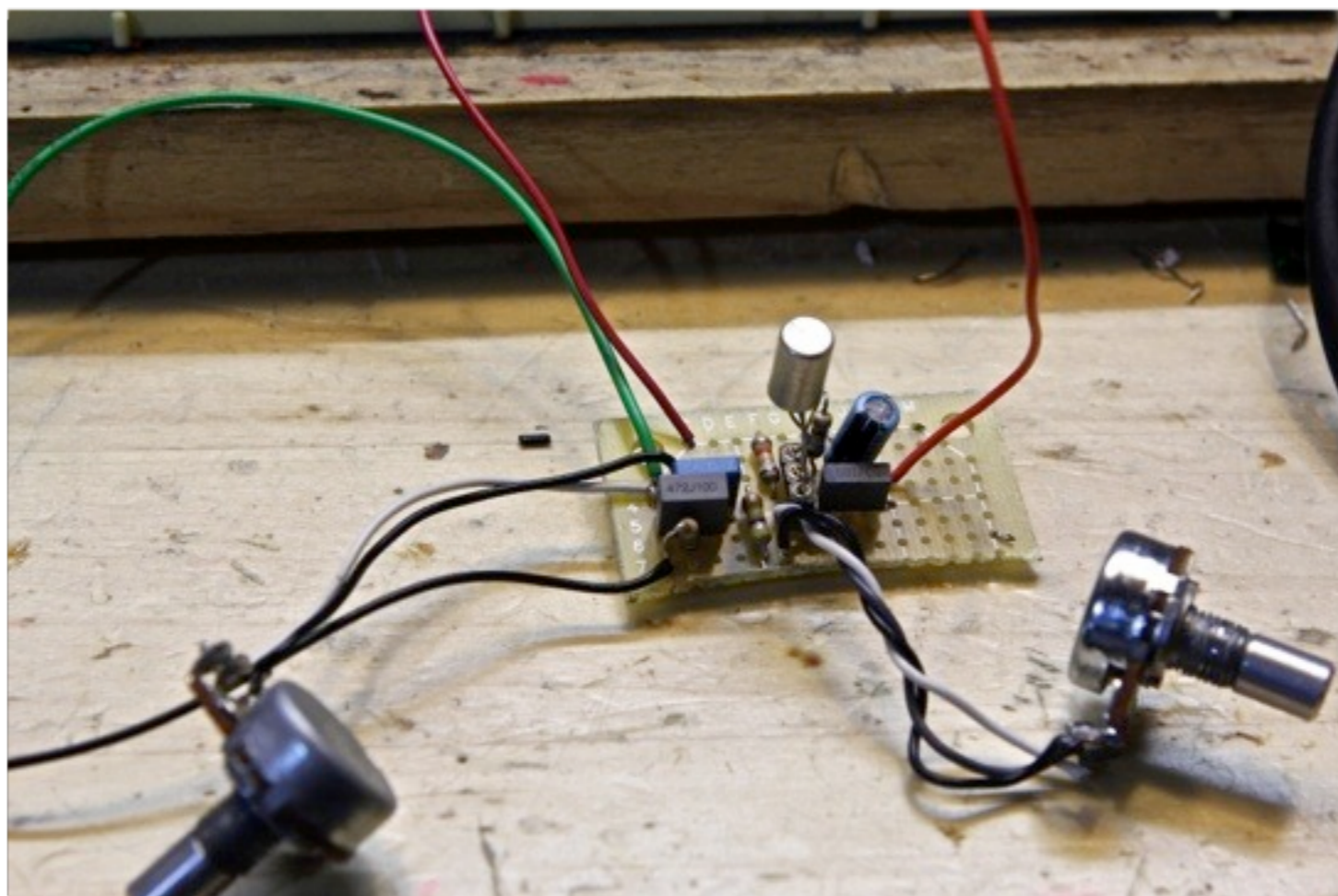

Connect an output wire to the rightmost leg of C2.

I've also inserted the transistor into the socket. Trim the wires short enough to keep things neat, but not *too* short, in case you ever want to reuse the transistor in another project.

Add the Extras

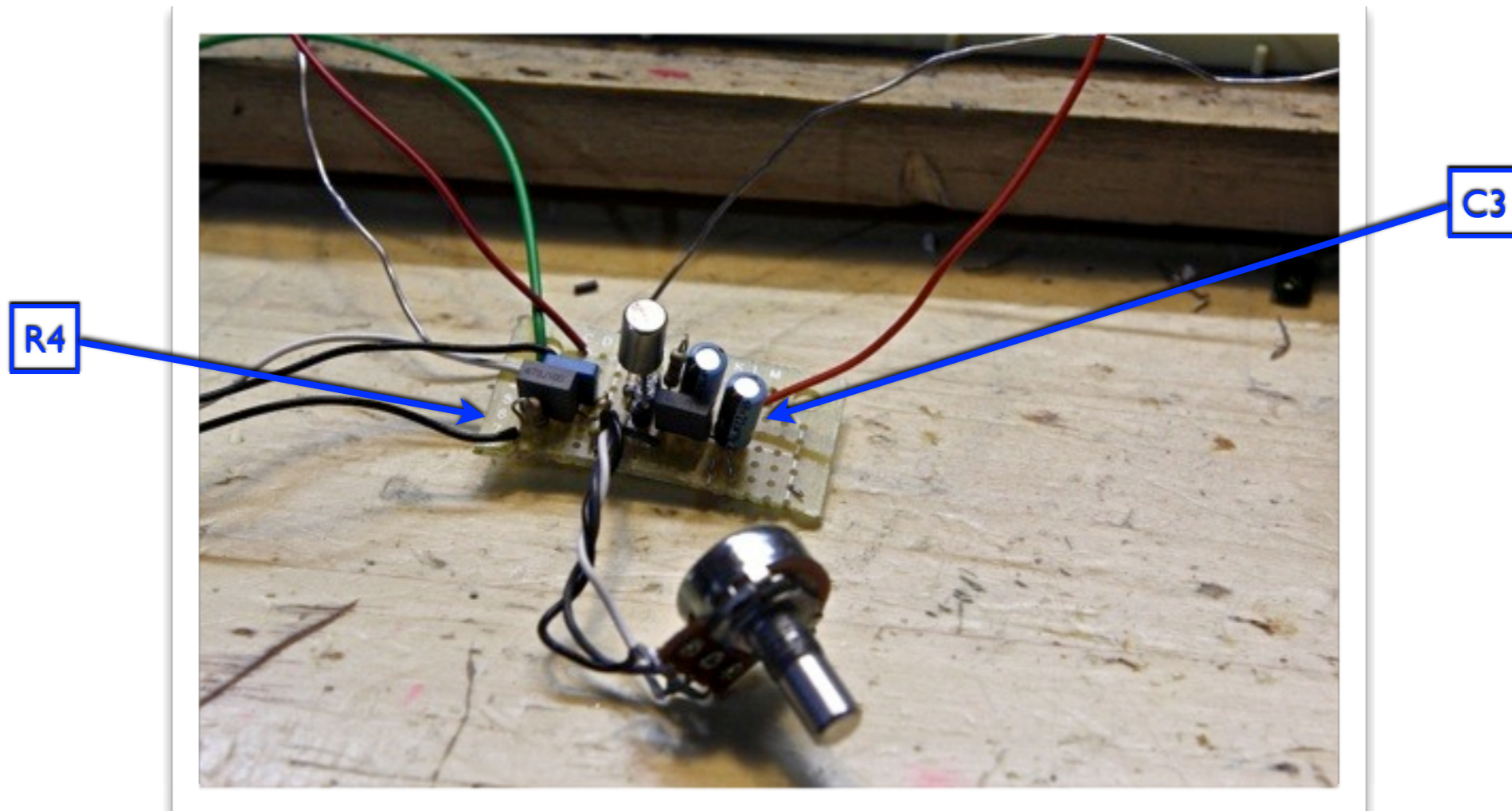

Connect the IM resistor (R4) between the cluster of wires at the input and ground. Place the other 22u electrolytic cap (C3) between the positive and negative busses. Place the 1N4001 diode (which I cleverly forgot to include in this photo) alongside it, with the banded end connected to the positive bus.

Add the LED wiring

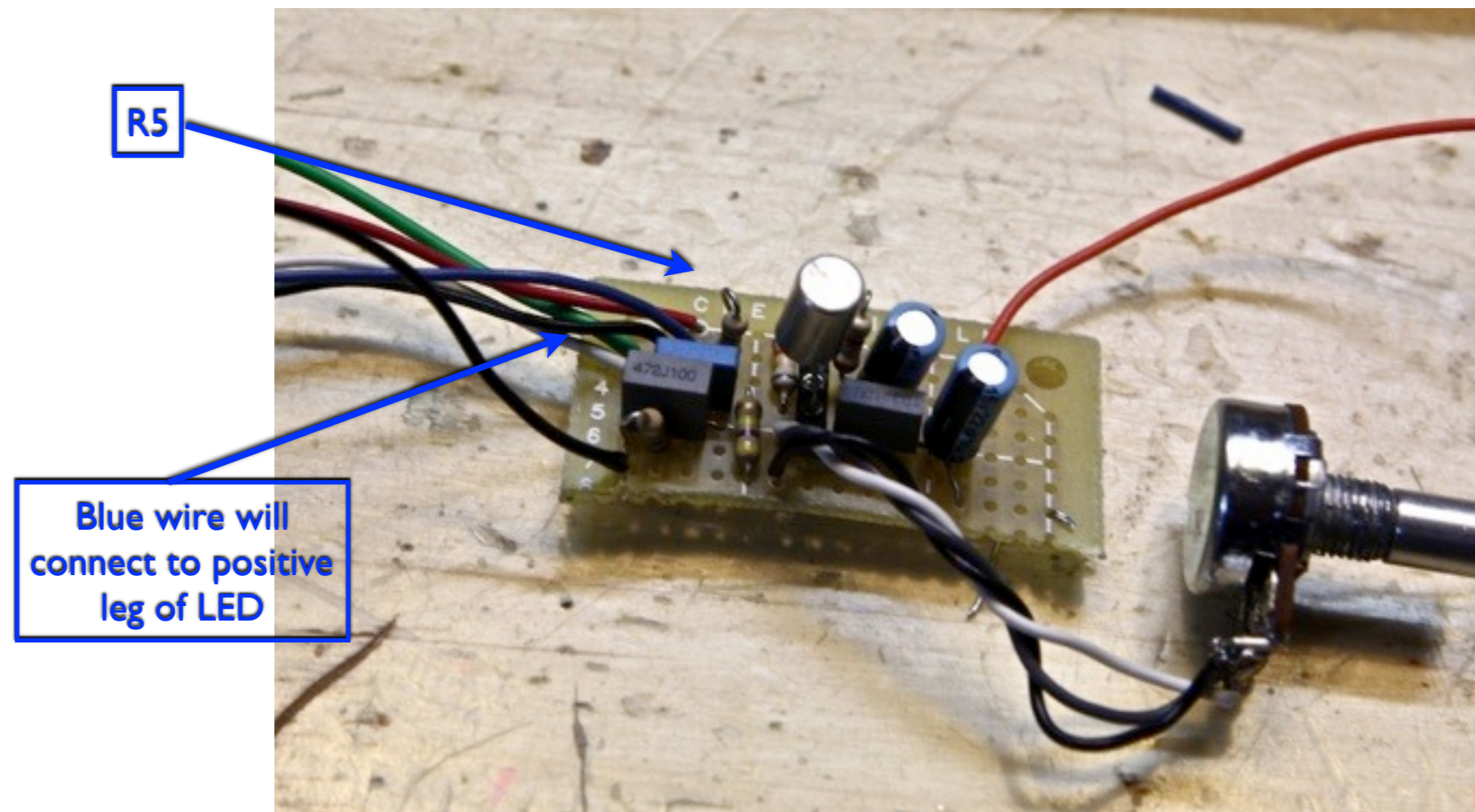

Connect one end of the 4.7K resistor (R5) to the positive bus. Tuck the other end of the resistor into a nearby hole, and attach it to a new wire, which will eventually connect to the positive leg of the power indicator LED.

Box It Up!

Install your circuit in the enclosure.

Project #1 includes step-by-step boxing instructions. The procedure is exactly the same here.

If the pedal stops working only when you screw down the back of the enclosure, something is probably shorting. You can apply bits of double-sided tape to trouble spots.

You should now have a ridiculously great-sounding pedal.

If not, post your problem to tonefiend.com's Project #4 thread. Chances are someone can help!



What could possibly go wrong?



tonefiend.com